

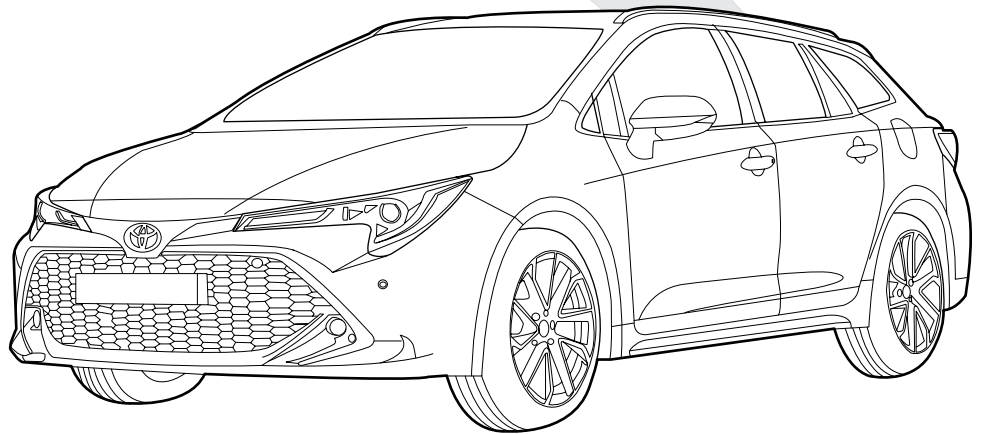

Toyota Corolla Touring + Facelift
Sports (type E21) 01/'24 -
02/'19 -

- ✓ STANDARD
- ✓ HYBRID
- ✗ OPTION "HANDSFREE TAILGATE"



Suzuki Swace Hybrid + Facelift
09/'20 - 03/'23 -

- ✓ STANDARD
- ✗ OPTION "HANDSFREE TAILGATE"

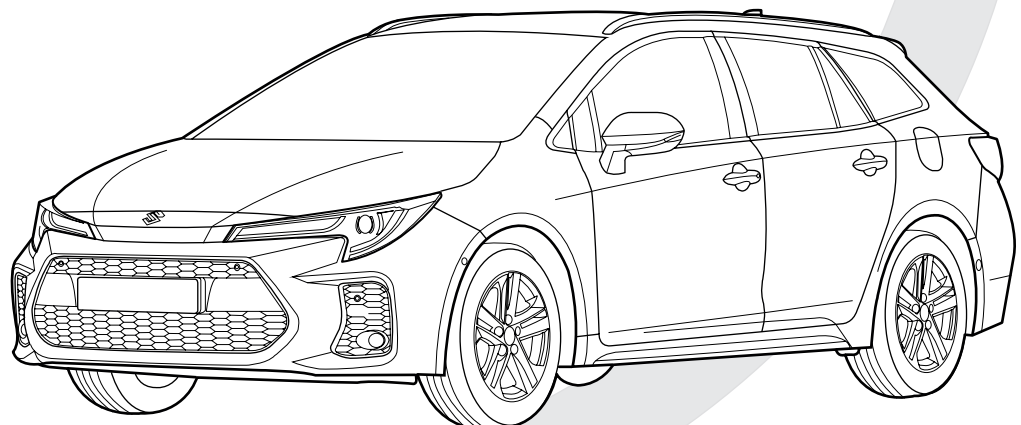

NL Belangrijke raadgevingen

Montage

- Voor de montage moet de trekhaak eerst op het voertuig gepresenteerd worden.

De belasting van een aanhangwagen en van een accessoire dat op de koppelingskogel wordt voorzien, zijn anders van aard. Voor beiden kunnen verschillende limieten van toepassing zijn. Hiervoor verwijzen we naar het instructieboekje van de wagen of naar uw concessiehouder.

FR Recommandations importantes

Montage

- Présenter l'attelage sous le véhicule avant d'effectuer le montage.

La charge d'une remorque ou d'un accessoire prévue sur la boule d'attelage, est de nature diverse. Pour ces deux éléments, il peut y avoir des limites d'utilisation. Nous vous recommandons de vous référer à votre livret d'instructions ou de vous renseigner chez votre concessionnaire.

EN General instructions

Fitting

- Present the towbar under the car first to check if all points are right.

The load of a trailer and of an accessory fitted on the towing ball are of a different nature. Different limits may apply to both. For this matter, we refer to the instruction manual of the vehicle or we advise you to contact your concessionaire.

DE Wichtige ratschläge

Montage

- Erst die Anhängerkupplung und das Fahrzeug kontrollieren, danach montieren.

Die Belastung eines Anhängers und eines Zubehörs, die man auf einer Kupplungskugel vorausieht, ist wesentlich anders. Für beide gilt, dass diese unterschiedlich begrenzt sein können. Deswegen möchten wir verweisen auf die Bedienungsanleitung des Fahrzeugs oder auf Ihren Vertragshändler.

ES Instrucciones generales

Montaje

- Presentar el enganche debajo del vehículo antes de realizar el montaje.

La carga de un remolque y un accesorio montado en una bola de remolque son de una naturaleza diferente. Se pueden aplicar diferentes límites a ambos. Para este asunto, nos referimos al manual de instrucciones del vehículo o le recomendamos que contacte a su distribuidor.

DK Generelle instruktioner

Montering

- Præsenter trækstangen under bilen først for at kontrollere, om alle punkter er rigtige.

Belastningen af en trailer og af tilbehør tilkoblet anhængertrækket er forskellige. Der kan være forskellige begrænsninger på begge. I disse tilfælde henviser vi til bilens manual, eller anbefaler dig at kontakte bilforhandleren

IT Consigli importanti

Montaggio

- In primo luogo, presentare la struttura sotto l'automobile per verificare che tutti i punti di attacco coincidano.

La massa rimorchiabile del veicolo potrebbe essere diversa dal valore riportato sul documento del gancio di traino. Per questo motivo, vi invitiamo a consultare sempre la carta di circolazione del veicolo (Pos. O.1) o a rivolgervi alla vostro concessionario di fiducia

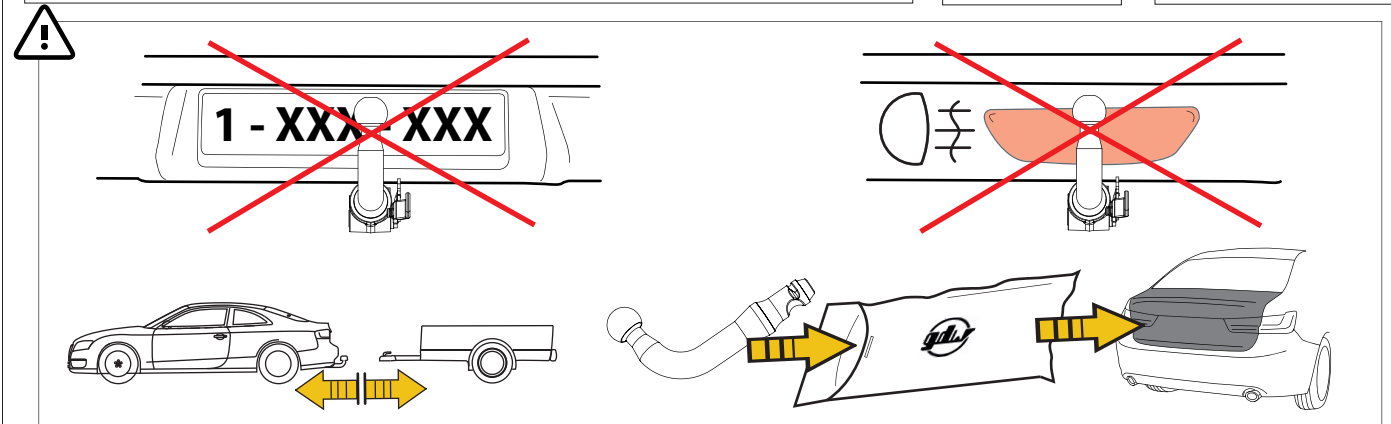
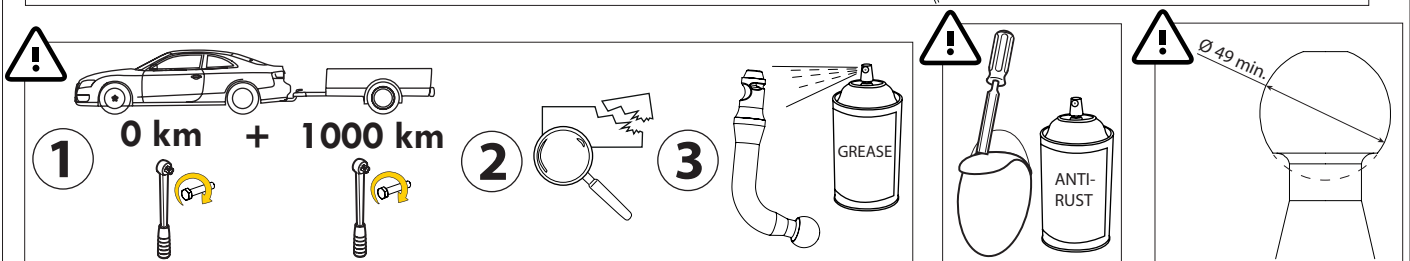
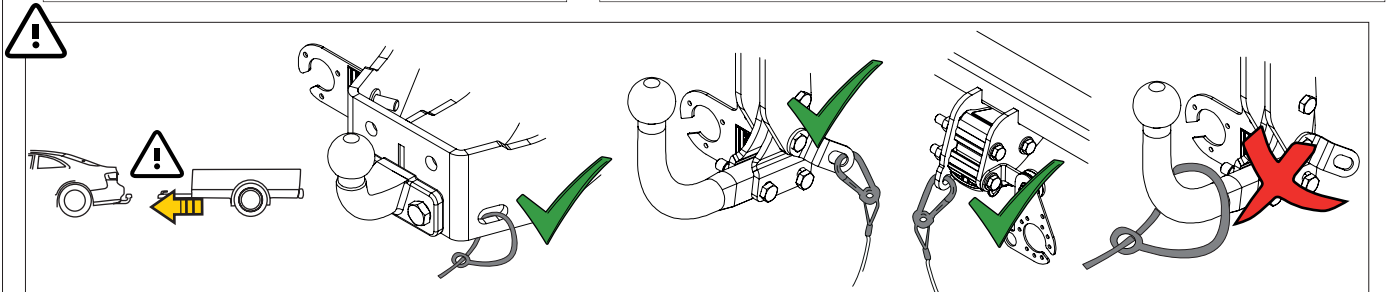
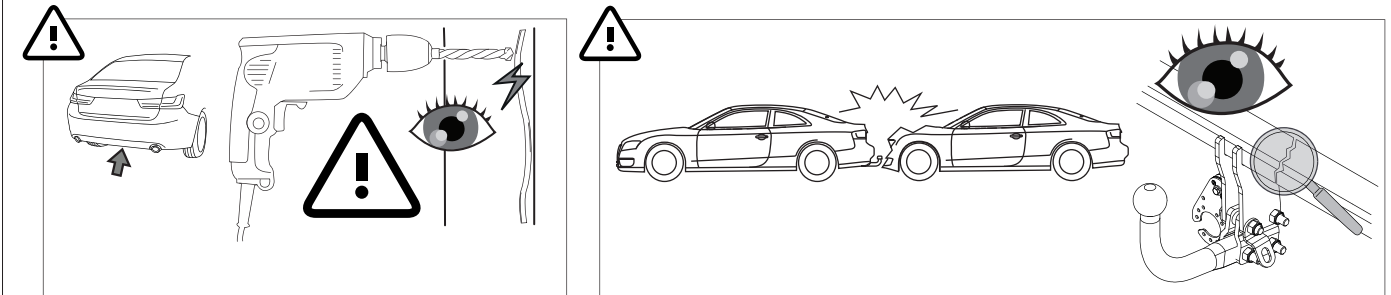
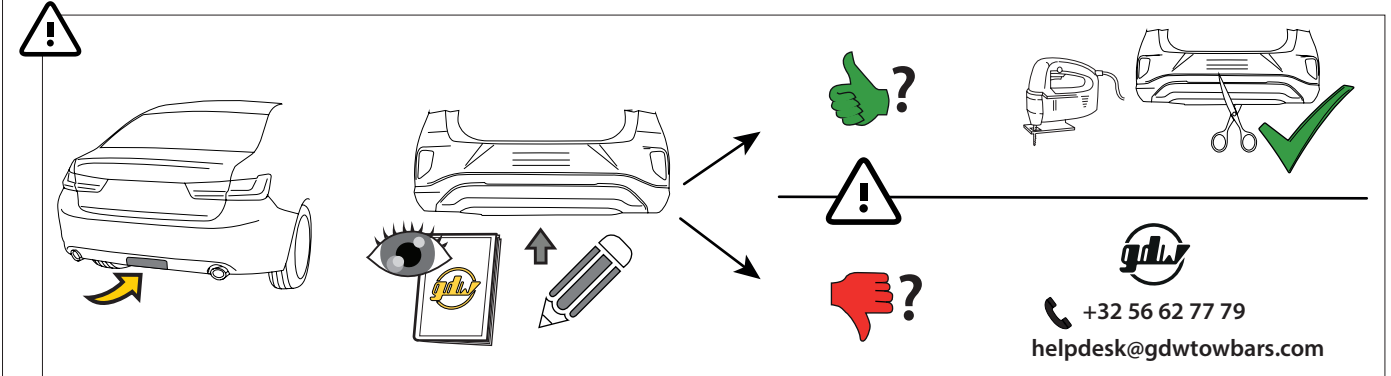
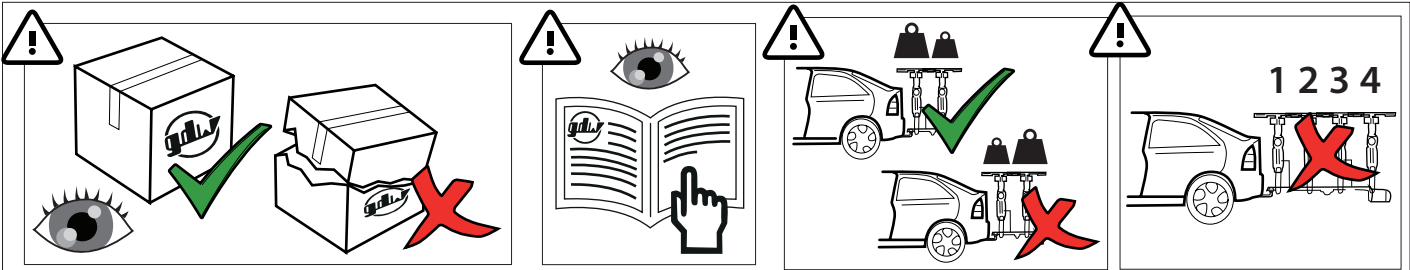

MADE BY  **D 8,60** **F** **E6**

BELGIUM **S 90** EC-N° 55R-01 1553

REF N° 2393T60 SERIAL N° XXXX

DESCRIPTION
Toyota Corolla Touring Sports 02/'19- + Facelift 01/'24-
Suzuki Swace Hybrid 09/'20- + Facelift 03/'23-

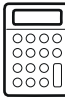

$$D = \frac{\text{max kg (car)} \times \text{max kg (trailer)}}{\text{max kg (car)} + \text{max kg (trailer)}} \times 0.00981 \leq 8,60 \text{ kN}$$

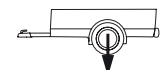
S =  ≤ 90 kg  ≤ 1550 kg

 See the Certificate Of Conformity (COC) of your vehicle or contact your dealer to verify the max. trailer weight of your car!

 See the user manual of the vehicle for correct use of bicycle carriers!

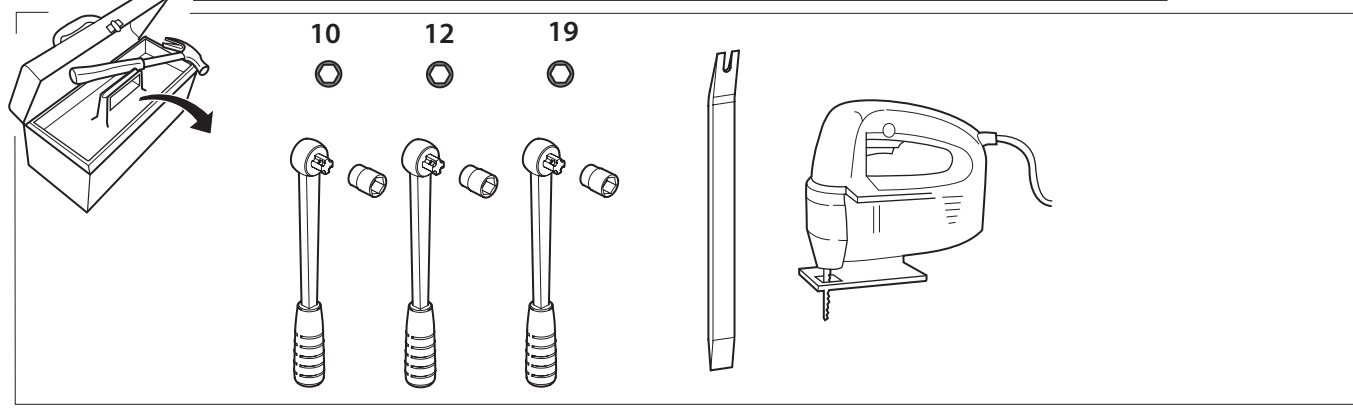
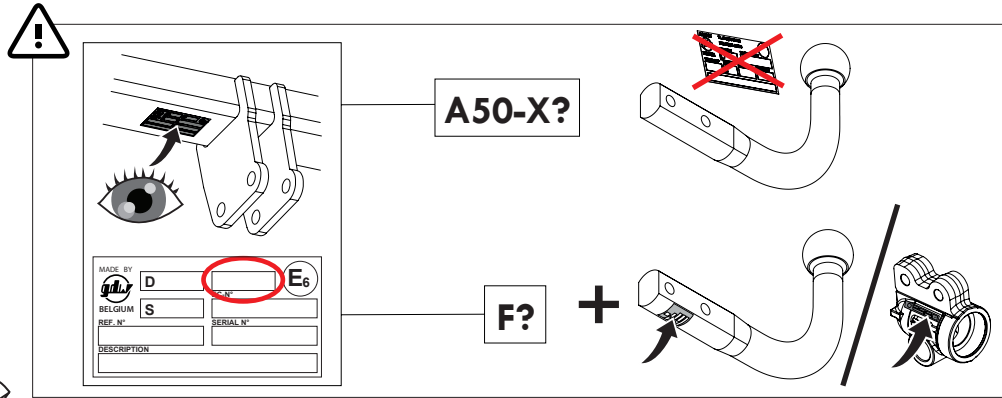
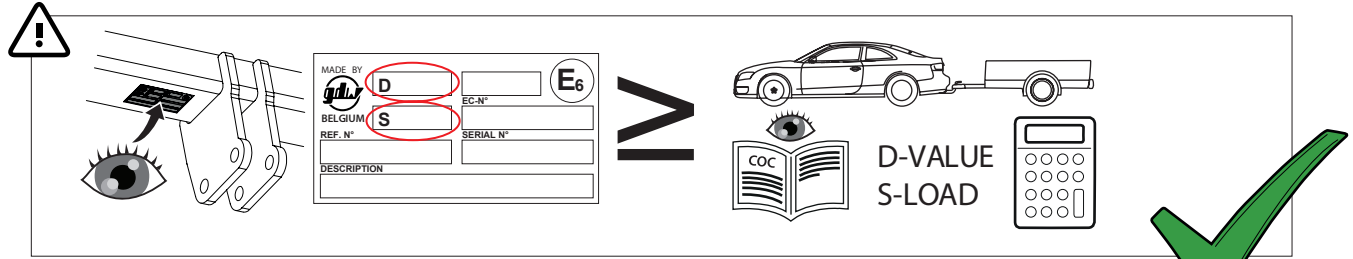
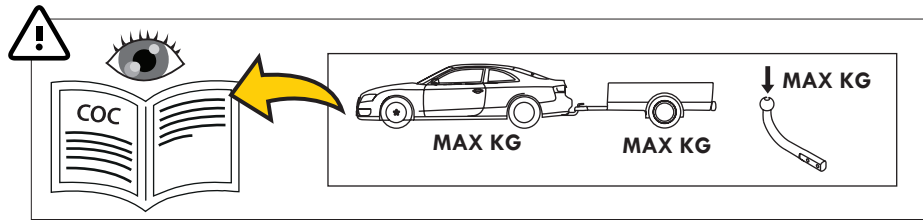

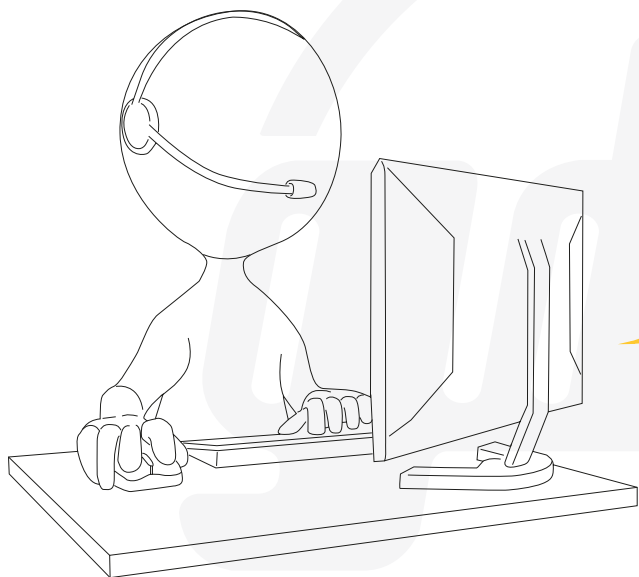







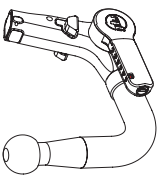

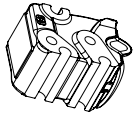
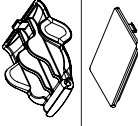
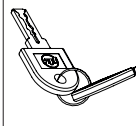
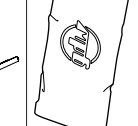
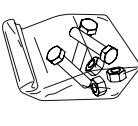
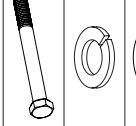
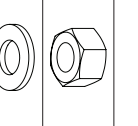



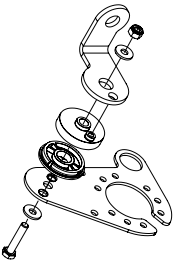

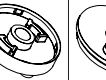

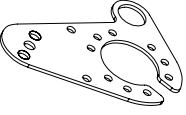
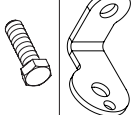
helpdesk@gdwtowbars.com
+32 56 62 77 79

Monday	08:00 - 12:00	12:30 - 16:30
Tuesday	08:00 - 12:00	12:30 - 16:30
Wednesday	08:00 - 12:00	12:30 - 16:30
Thursday	08:00 - 12:00	12:30 - 16:30
Friday	08:00 - 12:00	12:30 - 15:30

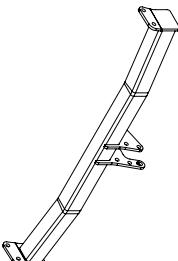
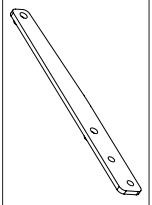
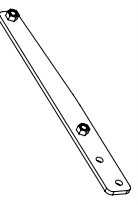

Geleverd met - Livré avec - Delivered with Gefiefert mit - Elementos adjuntos-Leveres med		GDW REF. 960.V0410		GDW REF. 740.200		GDW REF. 912.003		GDW REF. 740.112		GDW REF. 740.111		GDW REF. 740.114		GDW REF. 718.15.001		GDW REF. SYST60-10		DIN931-M12X110-8.8		DIN128A-M12		DIN125A-M12		DIN934-M12	
																									
X1		X1		X1		X1		X1		X1		X1		X1		X1		X3		X3		X6		X3	
L		L		L		L		L		L		L		L		L		L		L		L		L	

-P		X1	GDW REF. P39
L		X1	DIN935-M6
L		X2	6,2 X 15,4 X 1,6 (NYLON)
L		X1	GDW REF. 718.16.002
L		X1	GDW REF. 718.16.003
L		X1	GDW REF. 908.094
L		X1	DIN933-M6 X 30
L		X1	GDW REF. 908.095

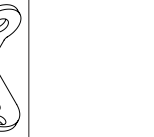
1		X1	GDW REF. 2393160
2		X1	GDW REF. 2
3		X1	GDW REF. 3
4		X4	DIN9021-M12-ELVZ
5		X8	DIN128A-M12
6		X8	DIN933-M12 X 40
7		X4	DIN125-A12-140HV- ELVZ
8		X4	DIN934-M12
-V		X1	GDW REF. 908.095

1

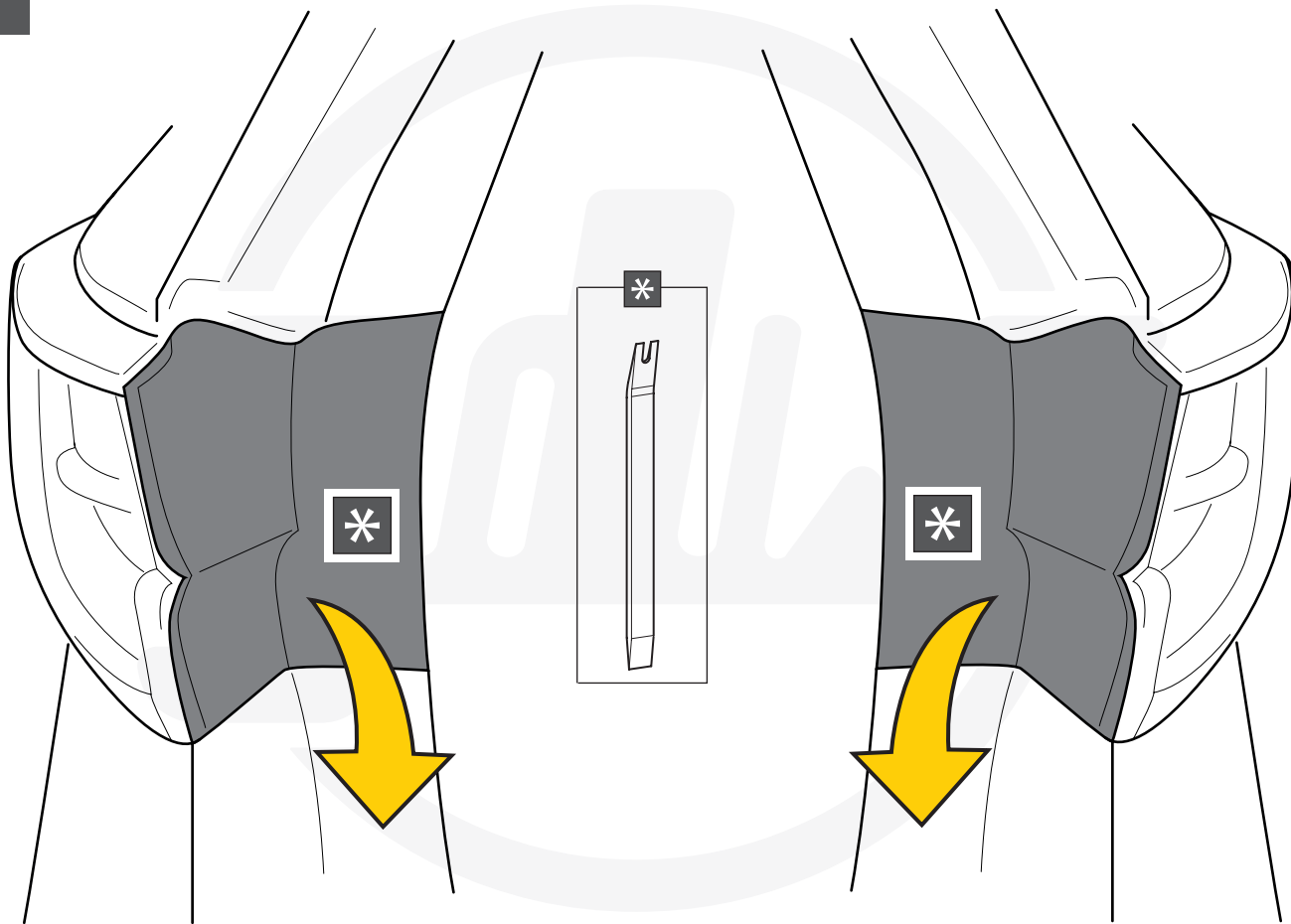

2

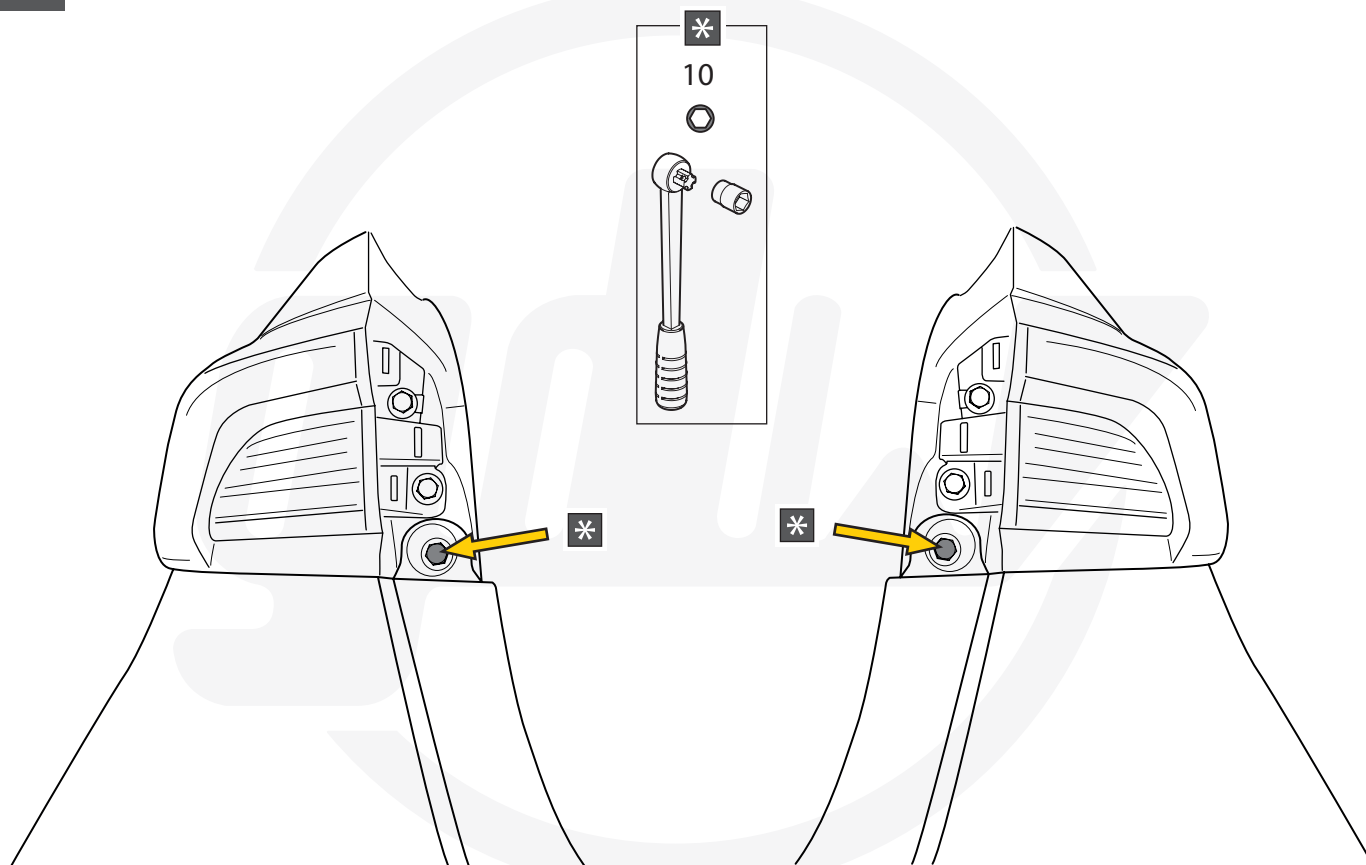

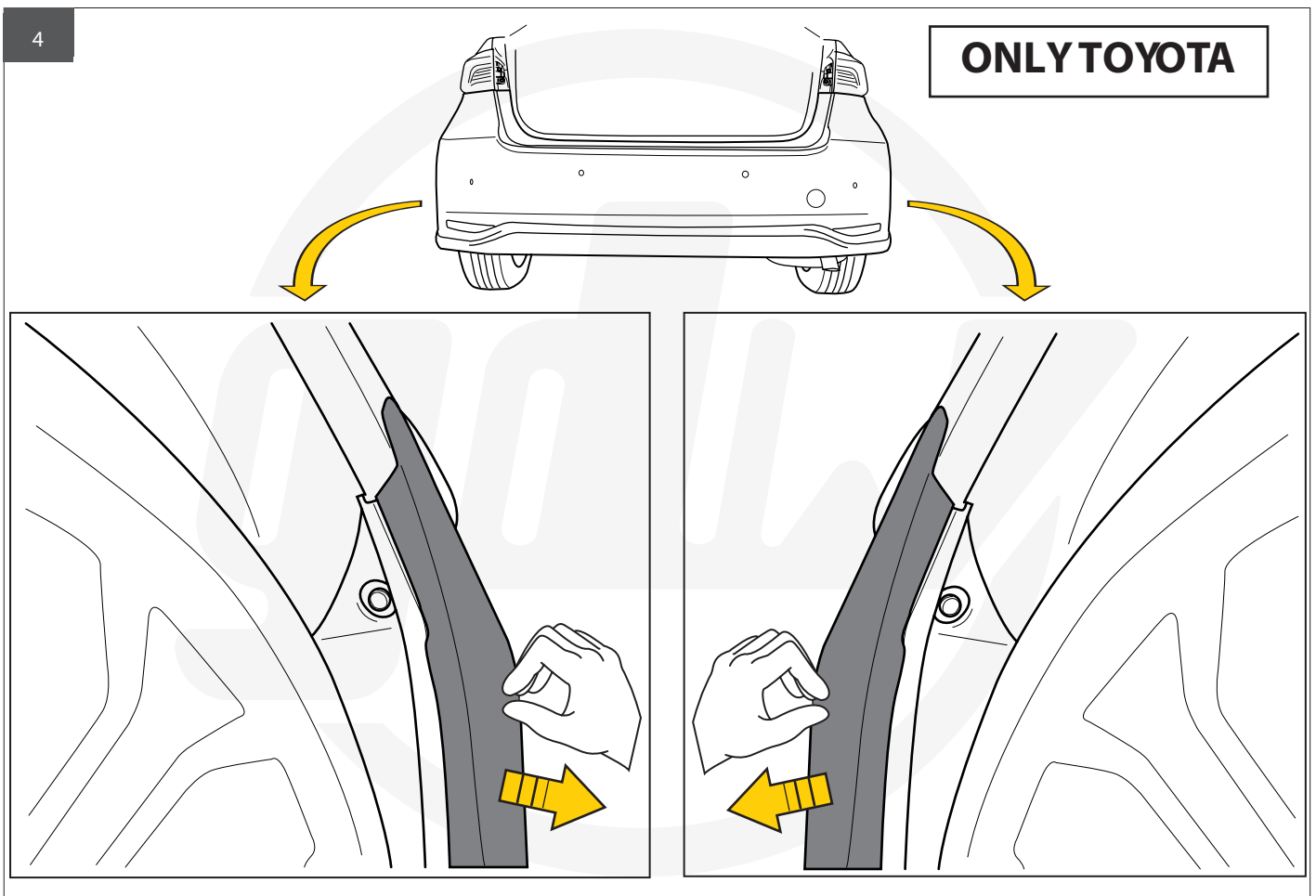
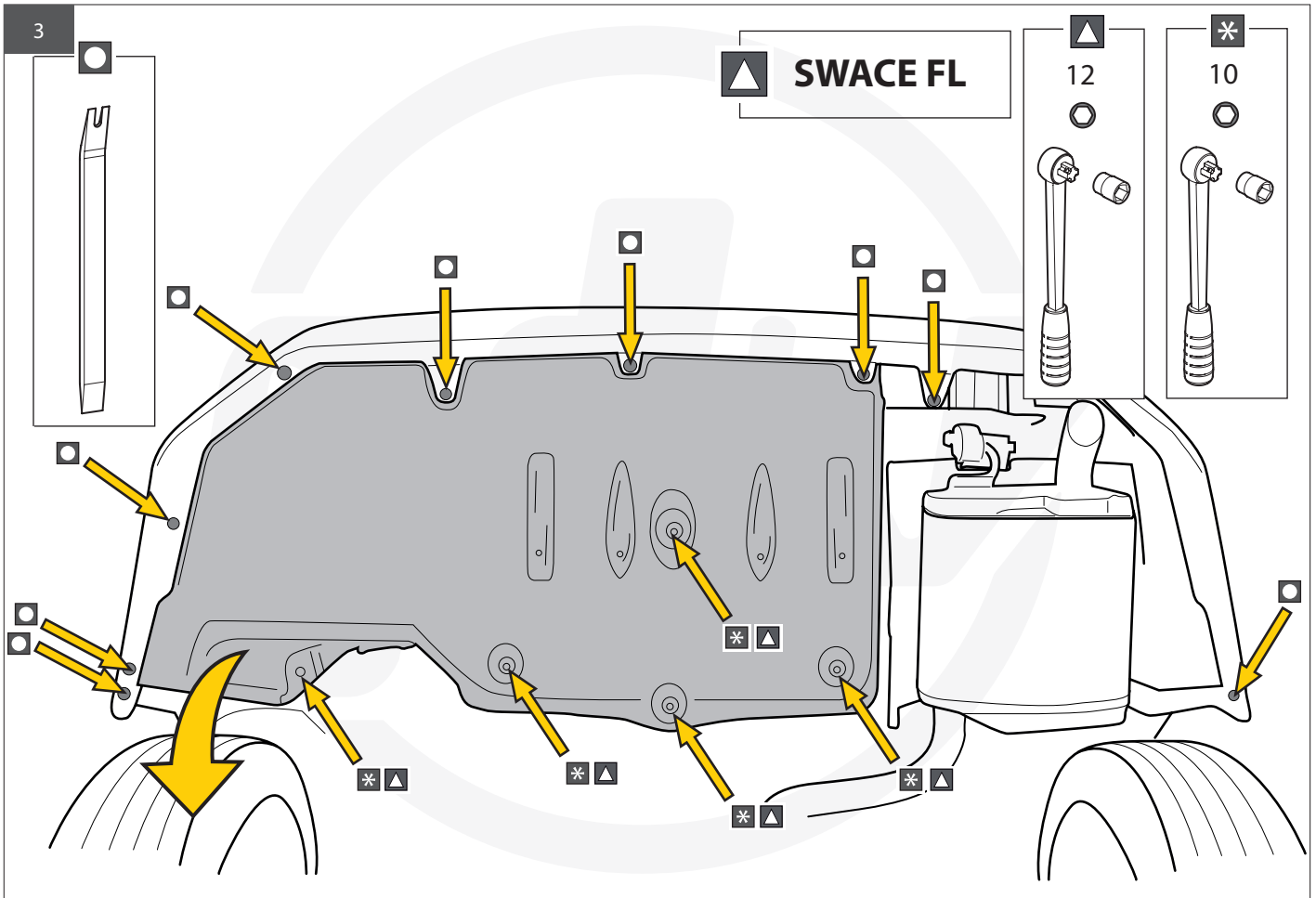

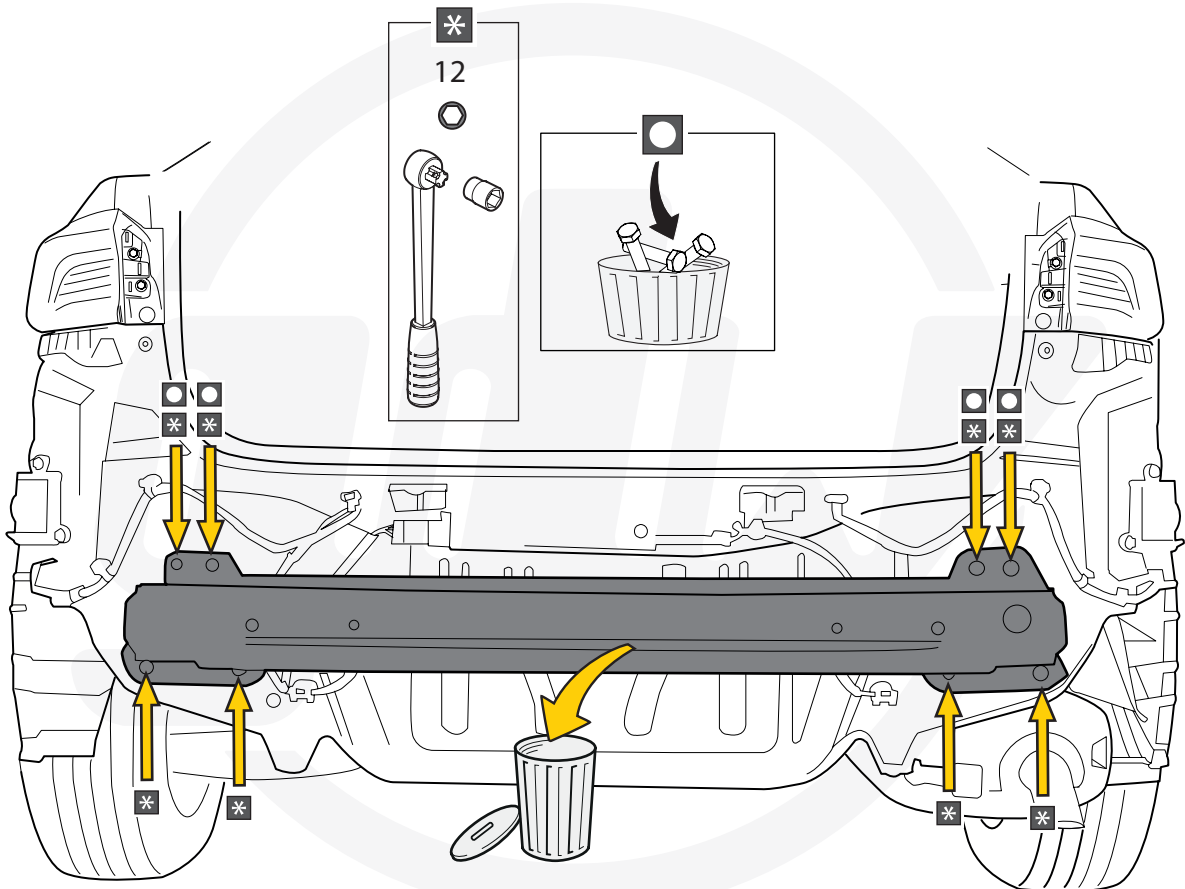
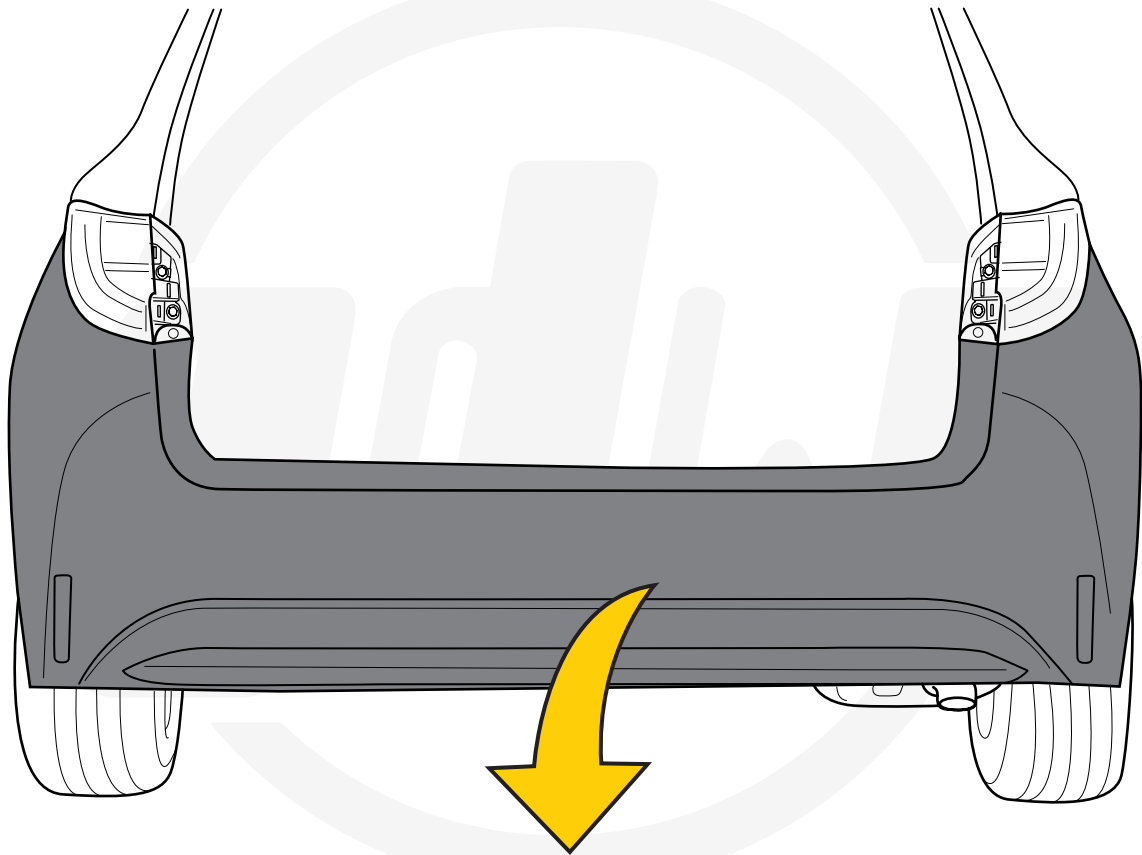

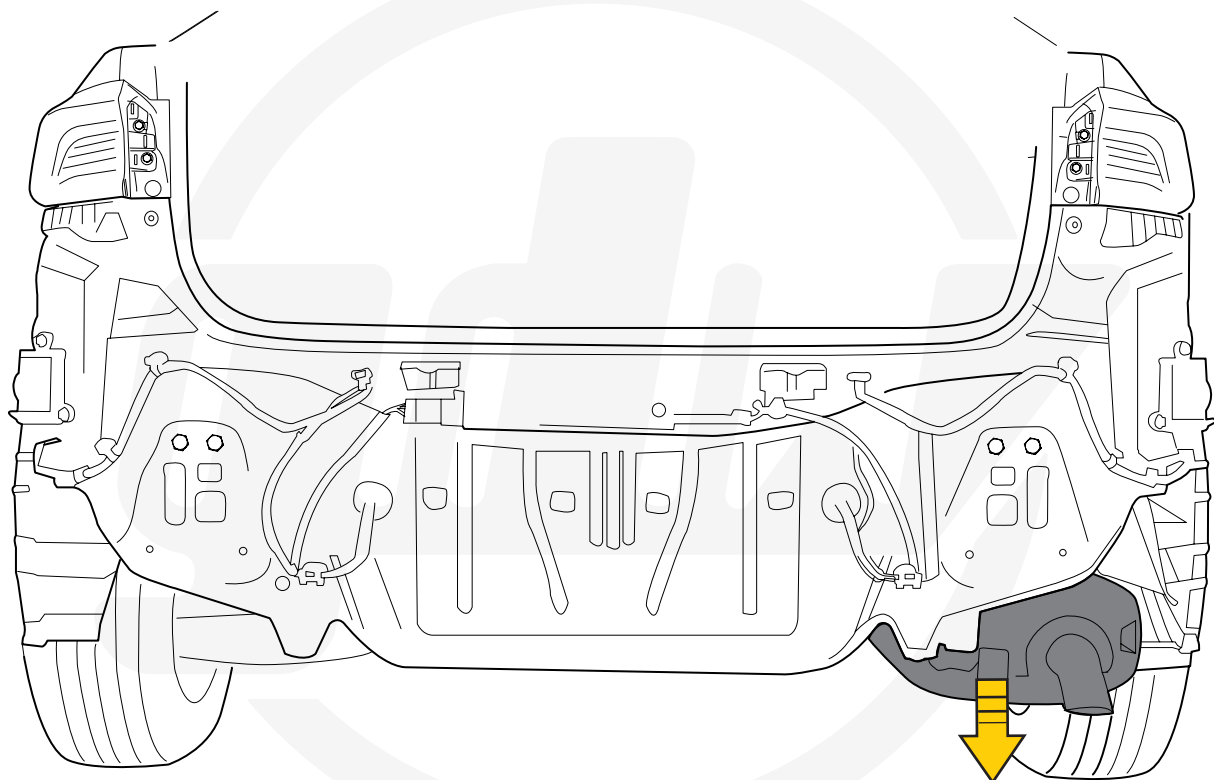
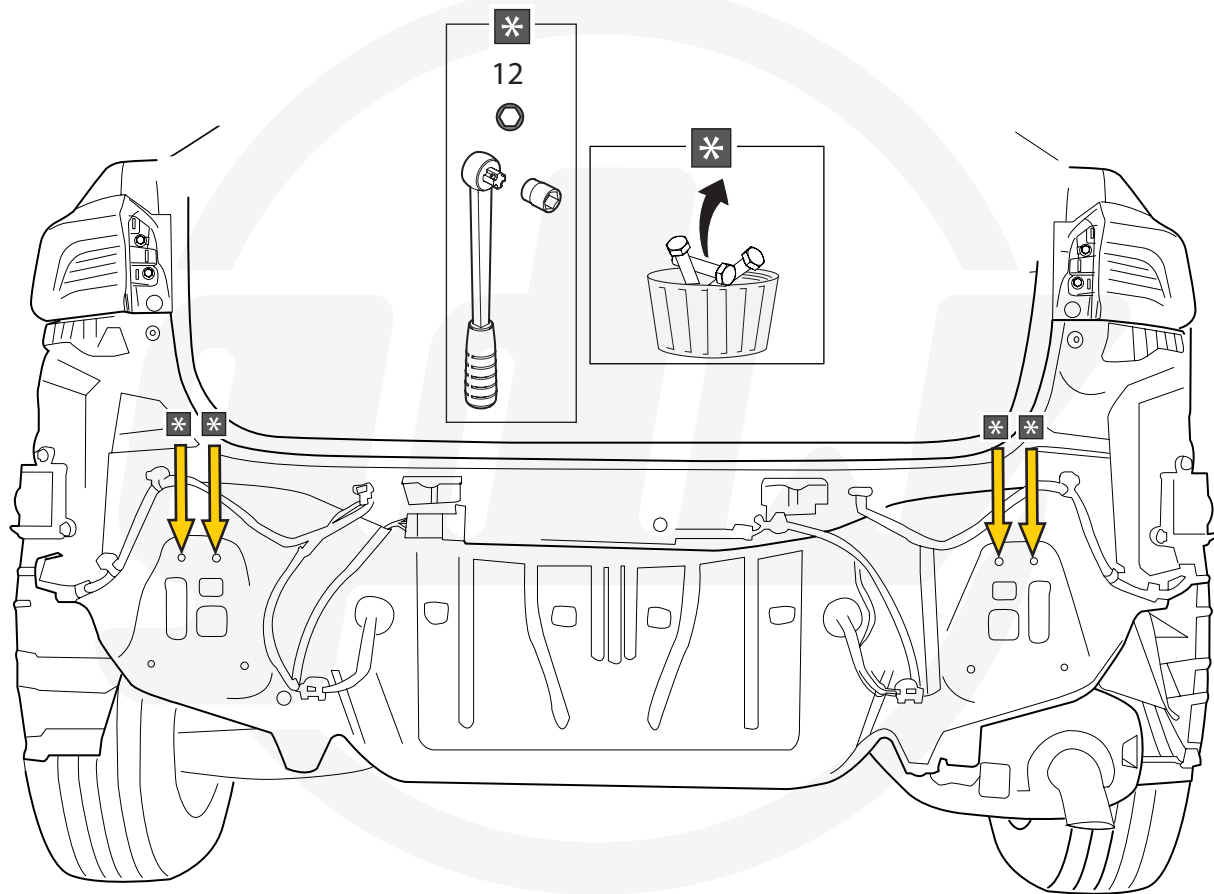

9

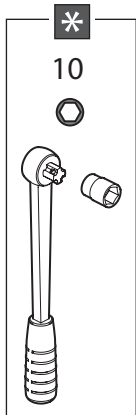
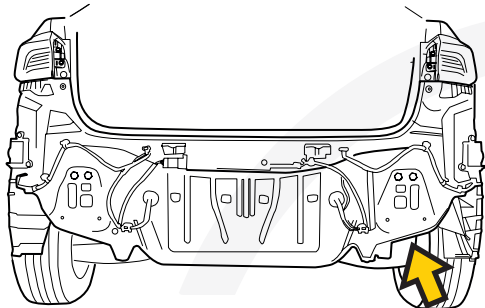

10

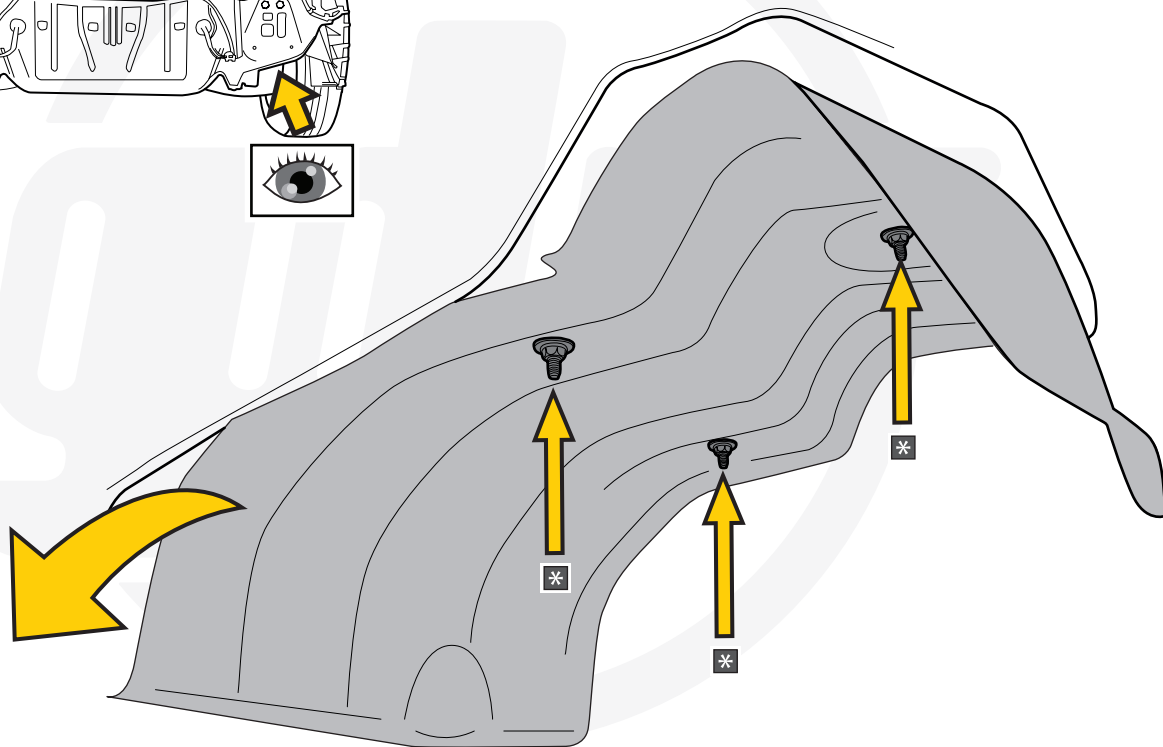

10

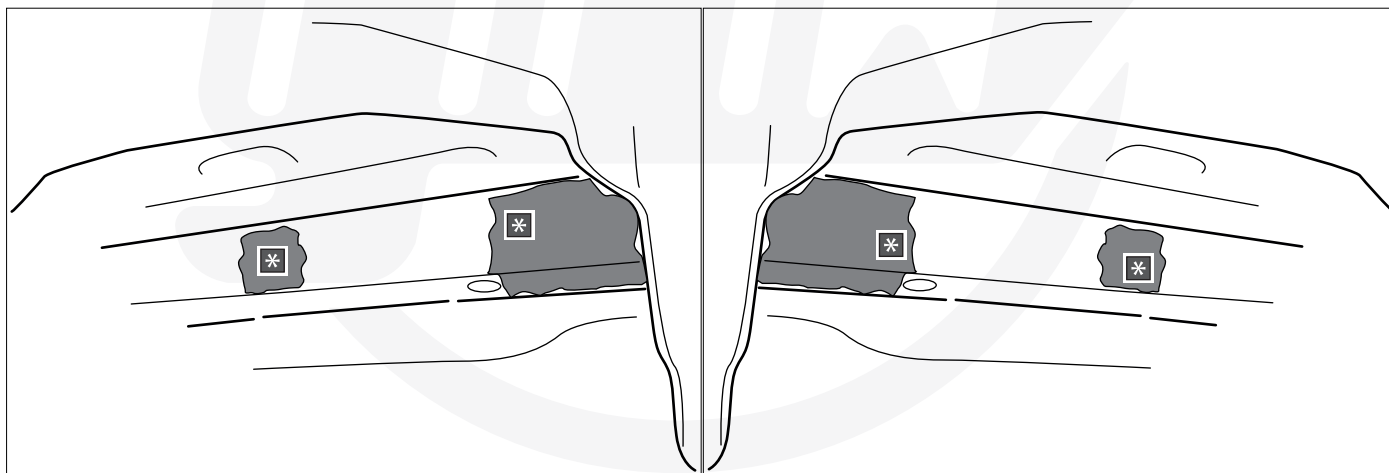
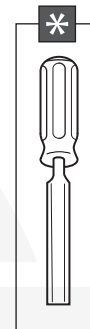
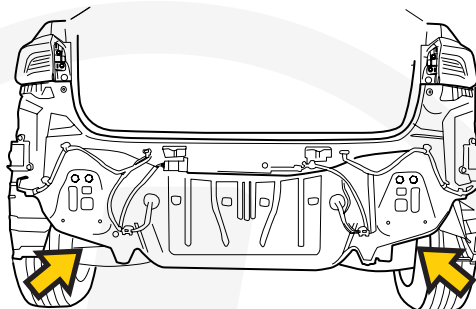

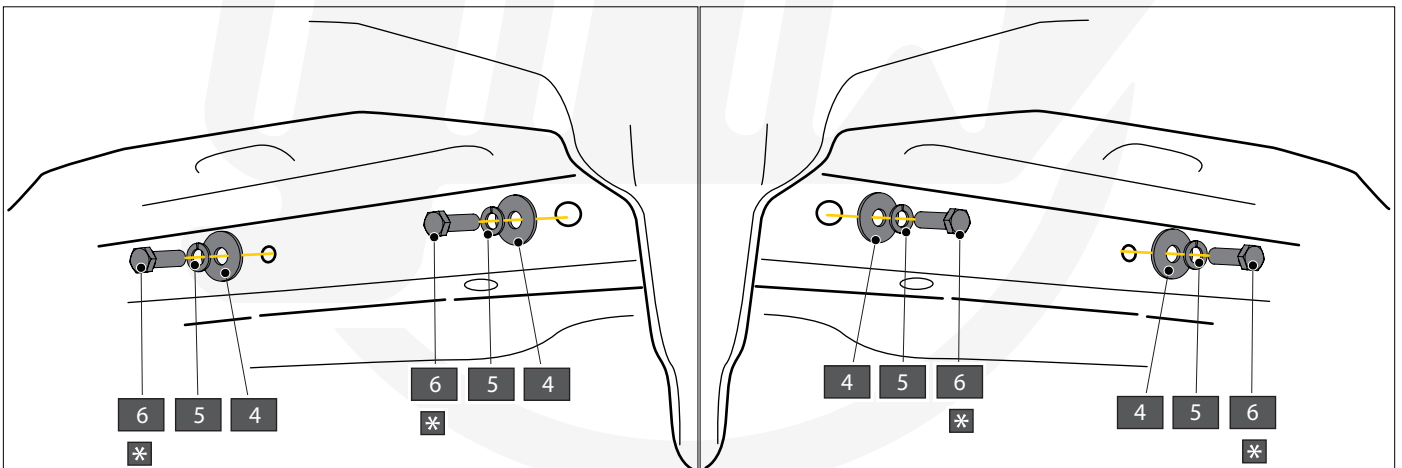
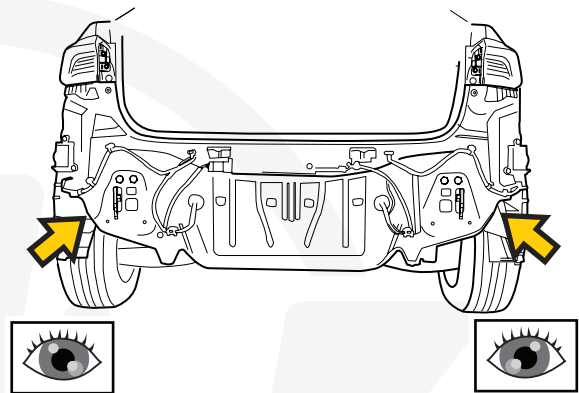
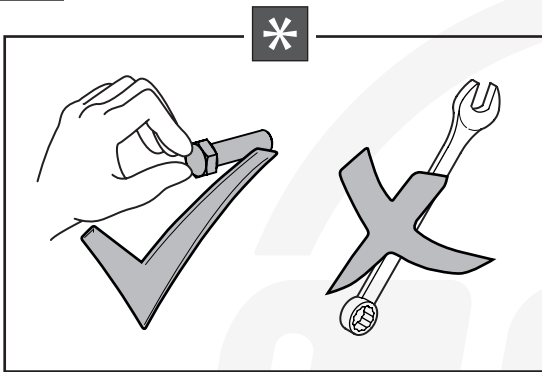
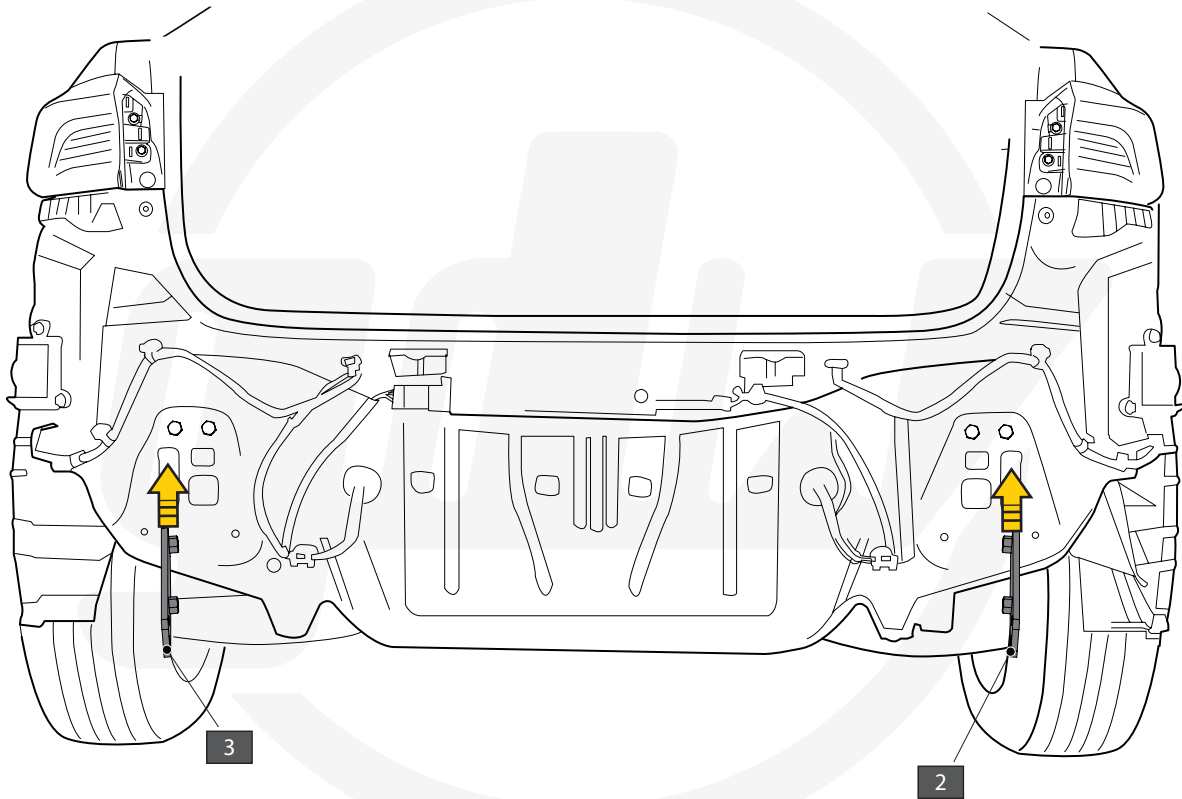

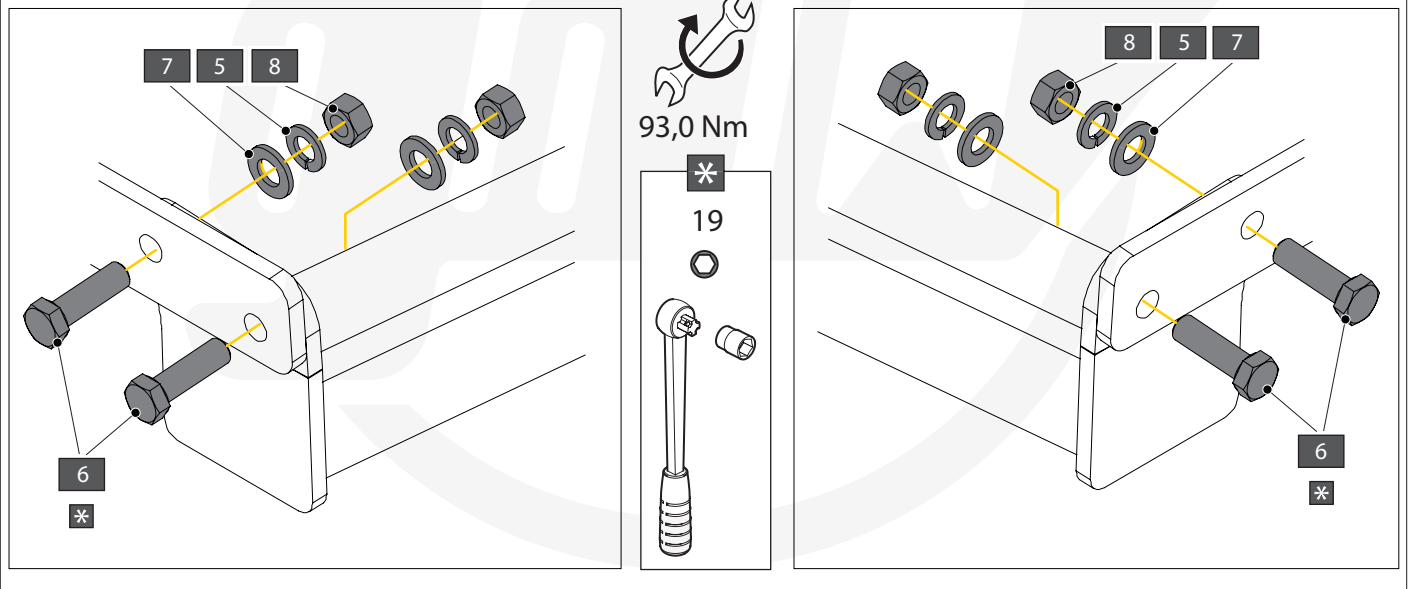
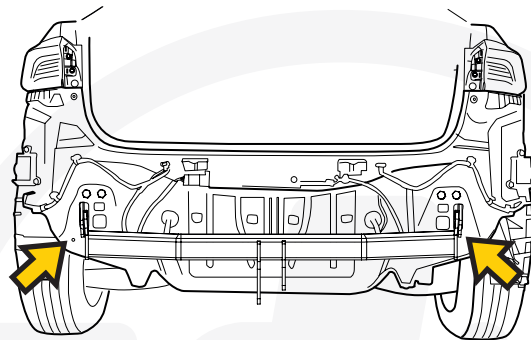
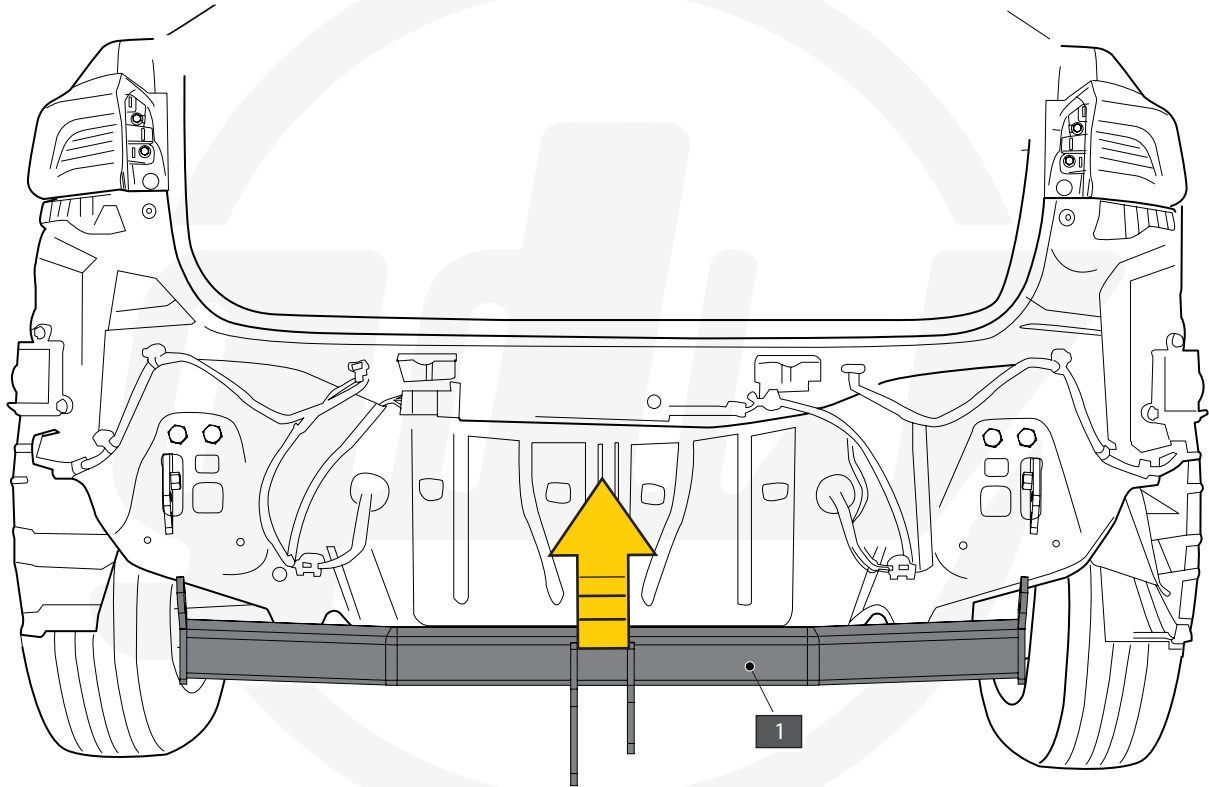

15

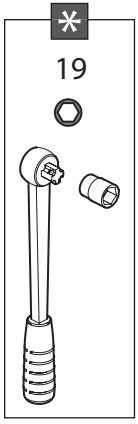

93,0 Nm

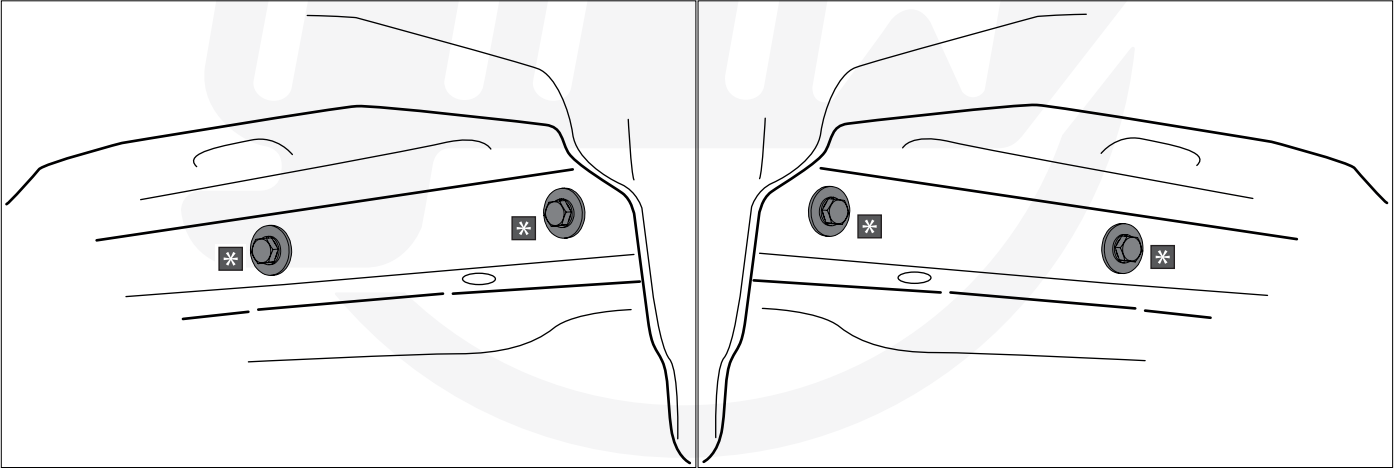
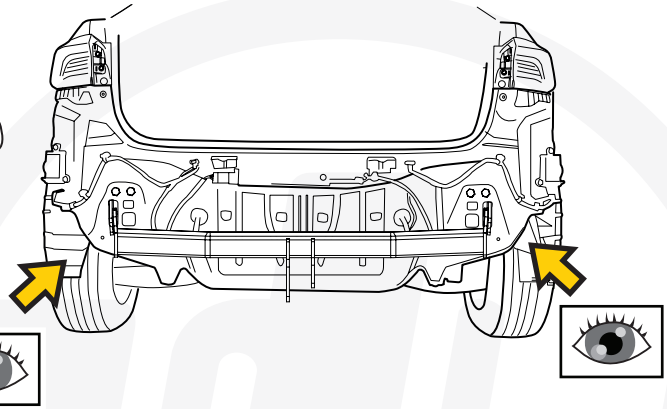

16

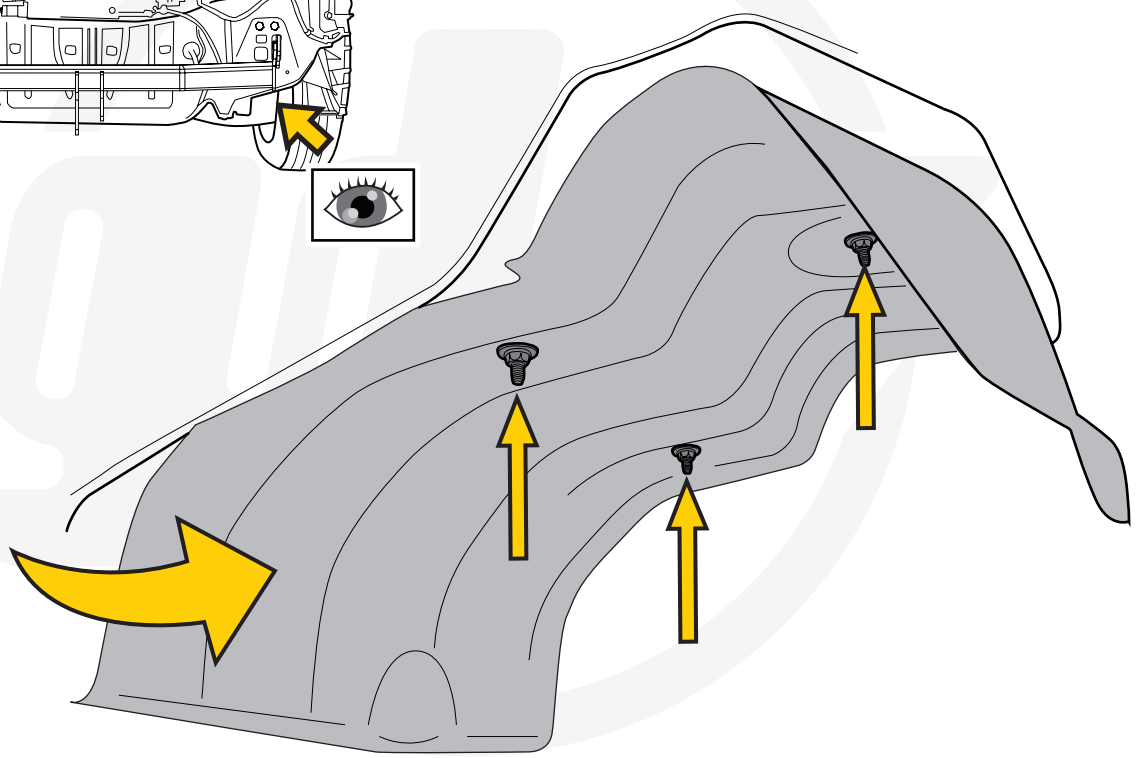
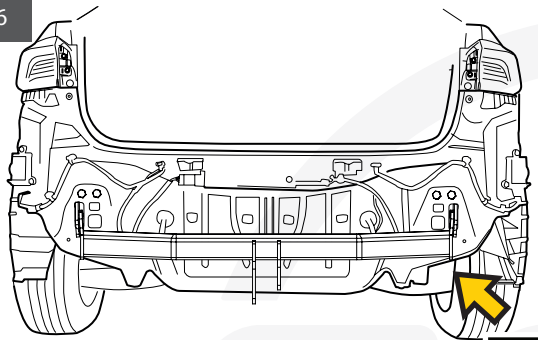

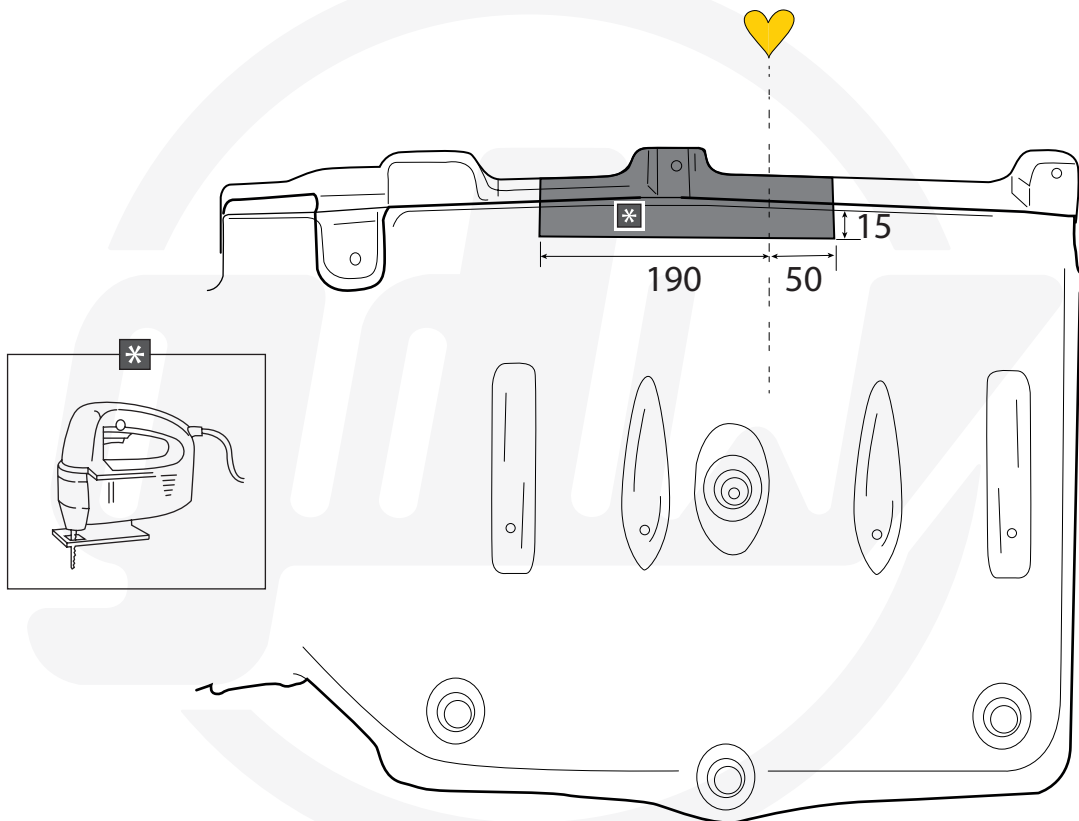
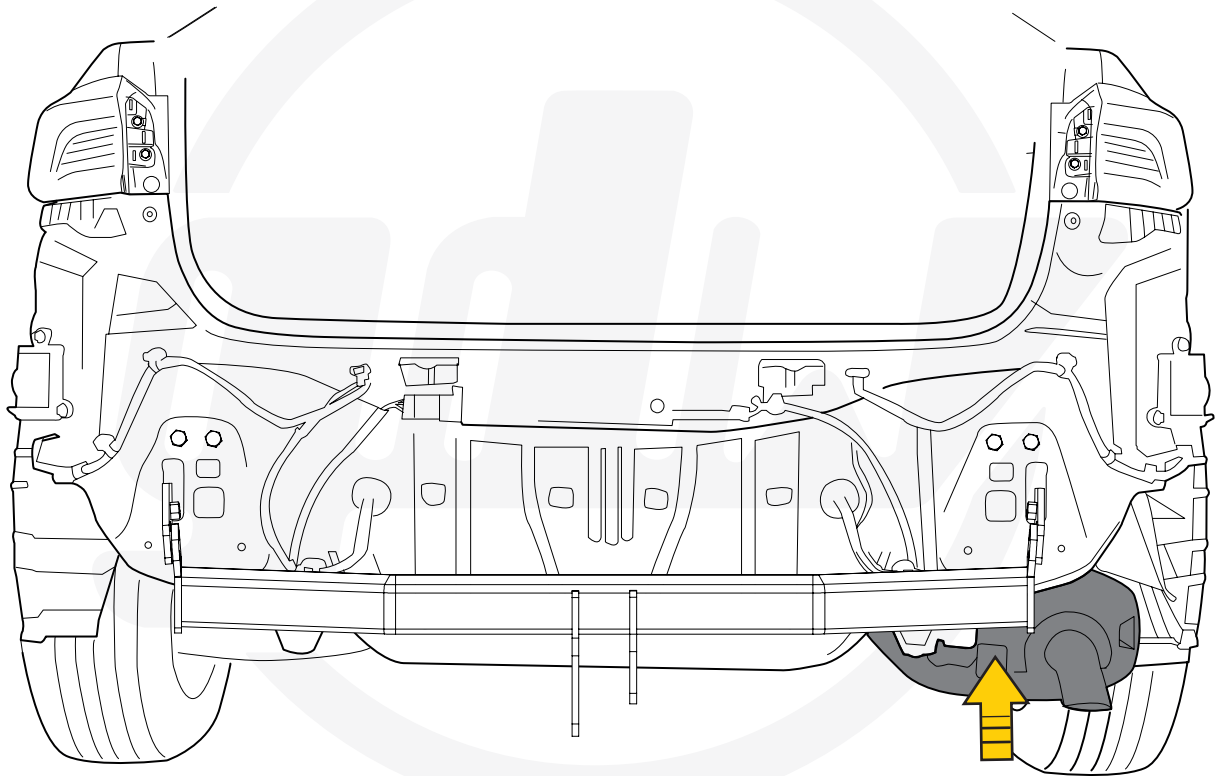

19



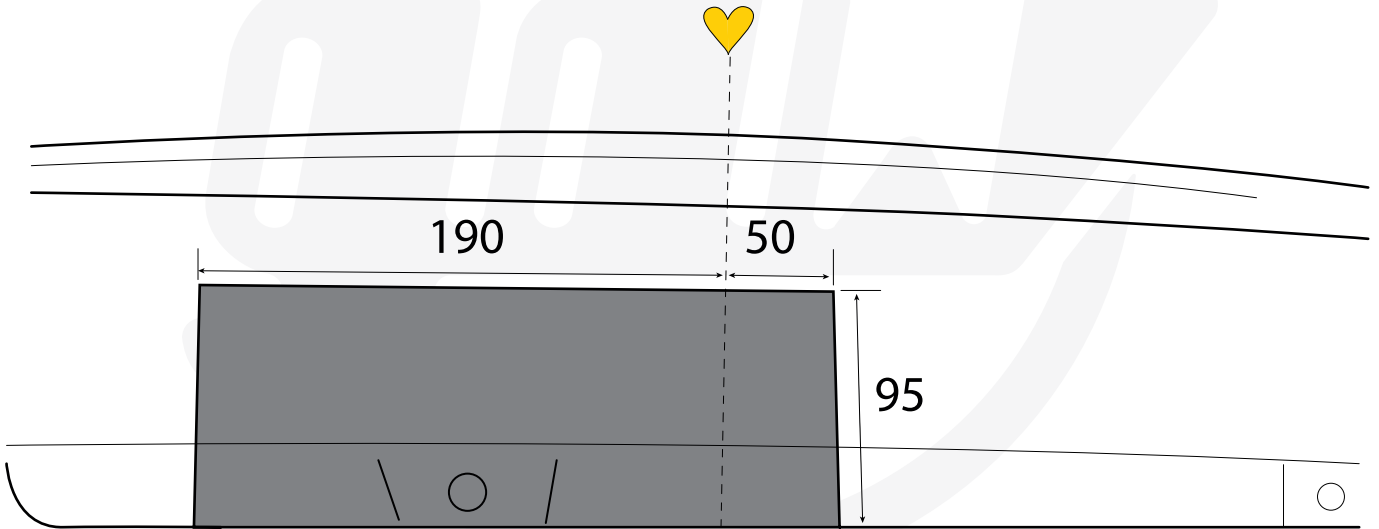
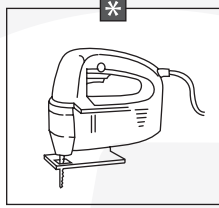
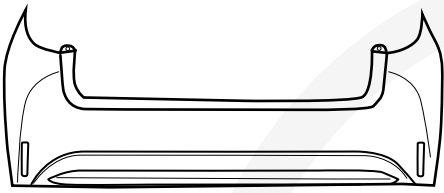



**TOYOTA MY 2019-2023
SUZUKI 2019-PRESENT**

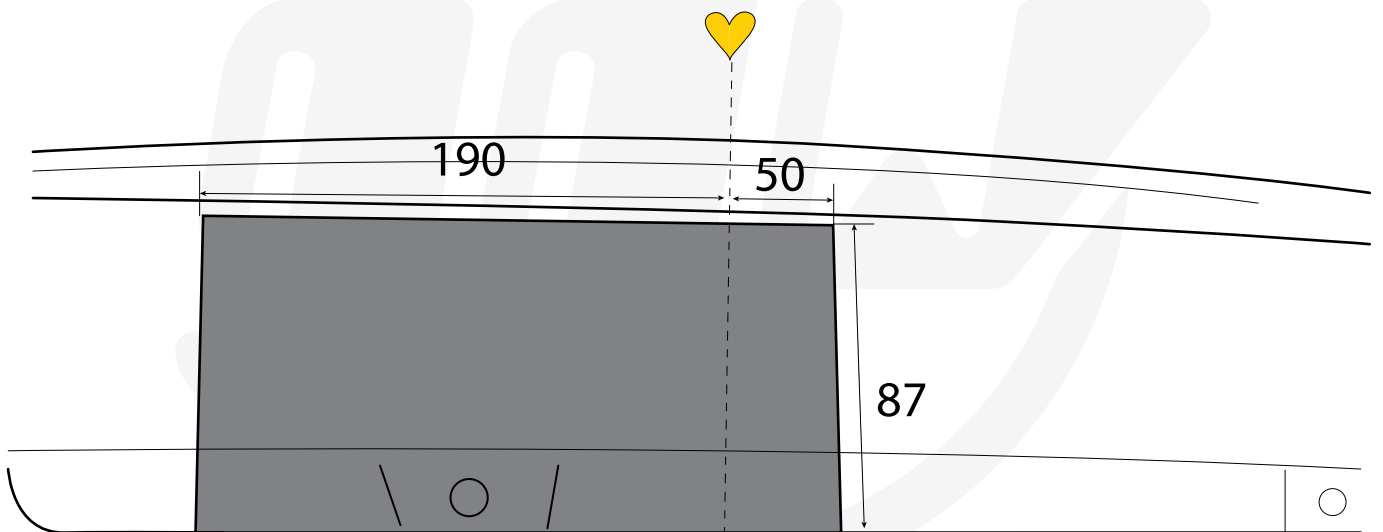
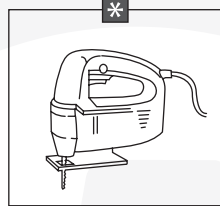

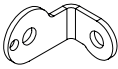

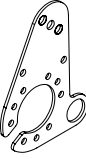

20

TOYOTA MY 2023- PRESENT

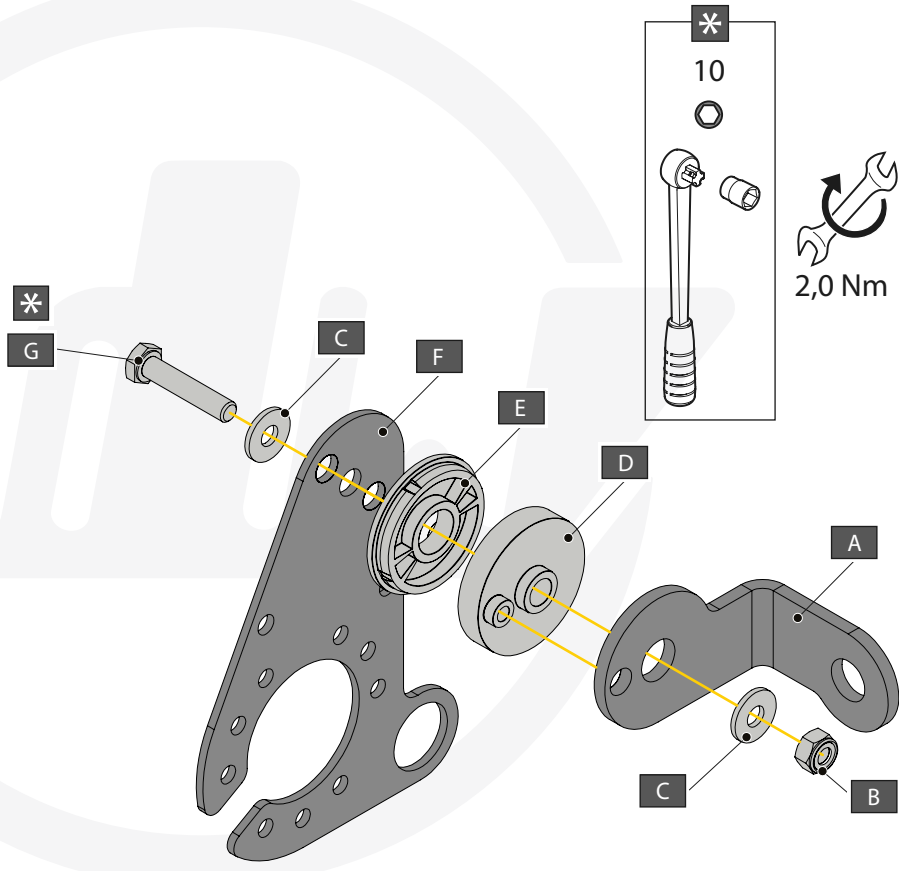

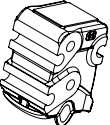
A		X1	GDW REF. 908.095
B		X1	DIN985-M6
C		X2	6,2 X 15,4 X 1,6 (NYLON)
D		X1	GDW REF. 718.16.002
E		X1	GDW REF. 718.16.003
F		X1	GDW REF. 908.094
G		X1	DIN933-M6 X 30



A		X1	GDW REF. 912.003
B		X3	DIN931-M12X110-8.8
C		X3	DIN128A-M12
D		X6	DIN125A-M12
E		X3	DIN934-M12

